

Introducing CollisionSentry™

**The signal that keeps people
and equipment safe around
corners and at intersections.**



New CollisionSentry creates a safer working environment in industrial buildings where forklift traffic and pedestrians intersect. Like a traffic light, CollisionSentry provides a visual warning to drivers and pedestrians that there is traffic around the corner.

Installs easily and virtually anywhere:

- Integrated fastener mounts
- Magnet mounts secure to racks in seconds
- No need for access or wiring to facility electrical system

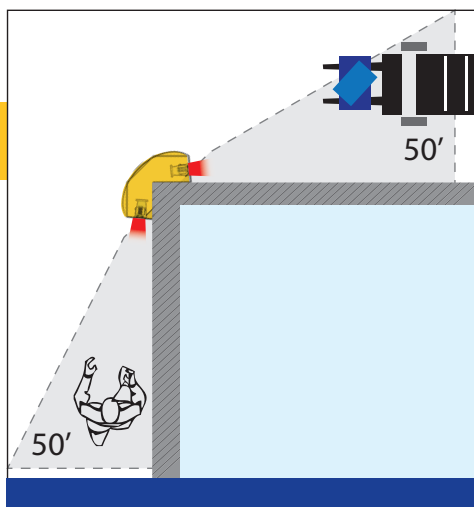

- **Dual motion sensors on each side provide maximum coverage and detection from up to 50' away**
- **Highly visible LED lights flash warning if there is motion on both sides of the corner**
- **Flash-always mode warns of on-going work in a corridor or aisle**
- **Powered by common D-cell alkaline batteries designed to operate for 2 to 3 years before battery change, low-battery indicator light on bottom of device**



Sentry Protection Products
16927 Detroit Avenue, Suite 3
Lakewood, OH 44107 USA
(216) 228-3200 • 1-888-265-8660